

AV15 Solar Light (1.8km Visible Range)

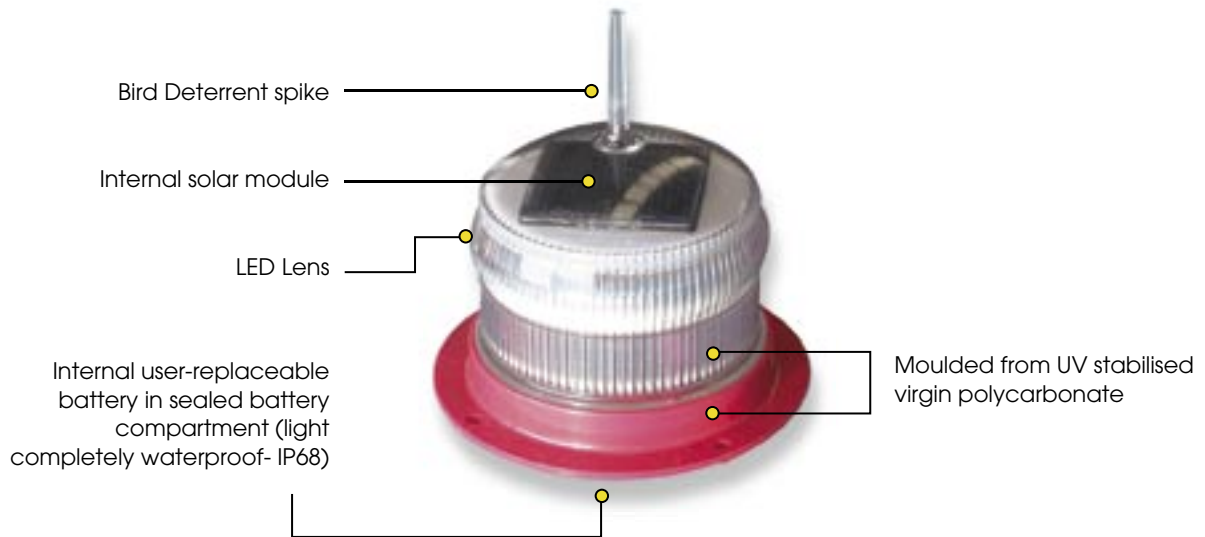

The AV15 is suitable for a range of applications including barricade lighting and general hazard marking, and is used by some of the world's largest mining companies to mark haul routes.

The AV15 solar-powered light is designed to be completely maintenance-free and have a service life of over 5 years.

During daylight hours the solar module will charge the battery, and the light will automatically begin operation at dusk - once the ambient light threshold drops sufficiently.

The AV15 features the LED 360° Reflector, which increases the intensity and uniformity of the horizontal output. The tough polycarbonate lens is specifically designed for use with LEDs, and incorporates an environment-friendly spike - deterring unwelcome bird life.

The unit is sealed using an advanced ultrasonic weld, enabling a rugged and completely waterproof seal capable of continuous environmental exposure.

The AV15 is also available with an optional ON/OFF switch for temporary installations such as worksites.



User-replaceable battery in sealed compartment.



AV15 with optional ON/OFF switch.



AV15 with optional 5kg non-slip rubber tile.



AV15 Solar Light (1.8km Visible Range)

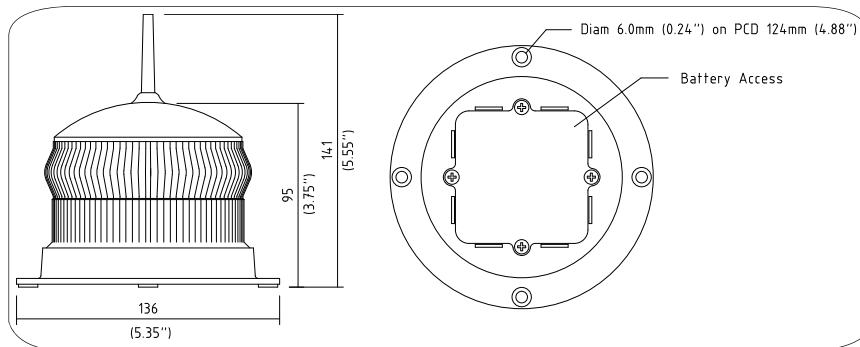

SPECIFICATIONS •

Light Characteristics

Light Source	4 ultra-high intensity LEDs
Light Color	Red, Green, White, Yellow, Blue
Intensity	>1.5cd
Horizontal Output	360 degrees
Vertical Divergence	9 degrees
Flash Settings	Available in a variety of flash settings including steady-on
Lamp Life	100,000 hours

Electrical Characteristics

Current Draw	Minimal
Circuit Protection	Integrated
Operating Voltage	3.6v
Autonomy	15 days (flashing)

Solar

Solar Module Type	Multicrystalline
Output	0.45watt

Power Supply

Battery Type	Environmentally friendly NiMH (Nickel Metal Hydride)
Battery Capacity	1.6Ah
Battery Voltage	3.6v

Physical Characteristics

Body Material	U.V. stabilised polycarbonate
Lense Material	U.V. stabilised / optical grade polycarbonate
Mounting	4 * 6mm mounting holes
Height (cm/inches)	14.1/5.55
Width (cm/inches)	13.6/5.35
Mass (Kg/lbs)	0.6/1.32

Certifications

CE	EN61000-6-3:1997, EN61000-6-1:1997
Quality Assurance	ISO9001:2000
Waterproof	IP68

Intellectual Property

Patents	US Pat. No. 6,667,582; AU Pat. No. 778,918
Trademarks	AVLITE is a trademark of Avlite Systems



• Specifications subject to change or variation without notice