

SLB600 / SLB610 600mm dia. Marker Buoy

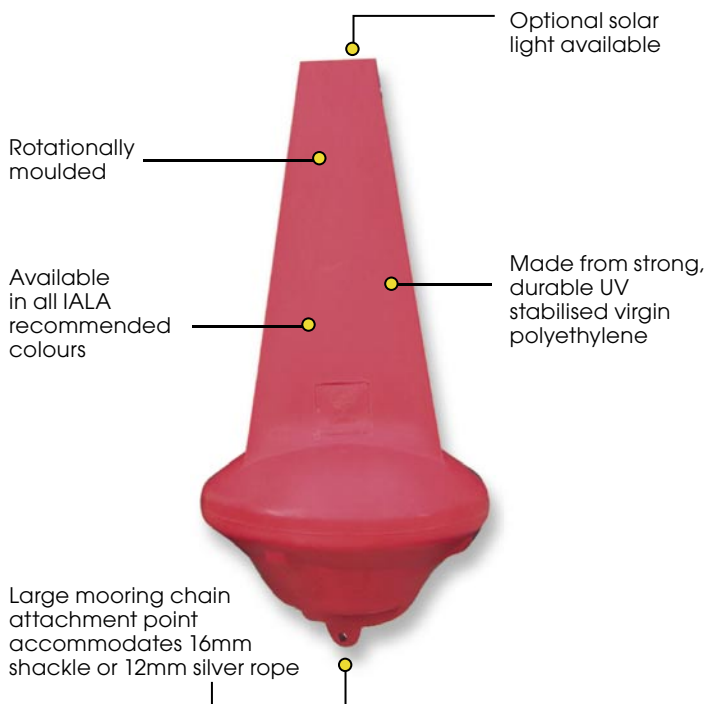

The SLB610 has an increased float section for additional buoyancy - aiding in deeper water installations.

The SLB600 is a short-range buoy ready for immediate installation. Typical applications include day and night channel, speed zone and restricted area marking.

The SLB600 is extremely long-lasting, and is moulded from strong, durable UV stabilised polyethylene. The base of the buoy is steel shot filled, and the top section is polyurethane foam filled, providing excellent buoyancy and stability. A large mooring chain attachment point accommodates a 16mm shackle or 12mm silver rope.

The complete assembly is only 16kg (32.2lb). The unit is available in standard high visibility Yellow, Green, Red and White.



One of 165 units installed as perimeter marking, Saudi Arabia



Head Office:
Sealite Pty Ltd
AUSTRALIA

Ph. +61 3 5977 6128
Fax. +61 3 5977 6124
Internet: www.sealite.com.au
Email: info@sealite.com.au

USA Customers;
Sealite USA
USA (Gifford, NH)

Ph. (603) 524-6066
Fax. (603) 524-8100
Internet: www.sealiteusa.com
Email: info@sealiteusa.com

SLB600 / SLB610 600mm dia. Marker Buoy

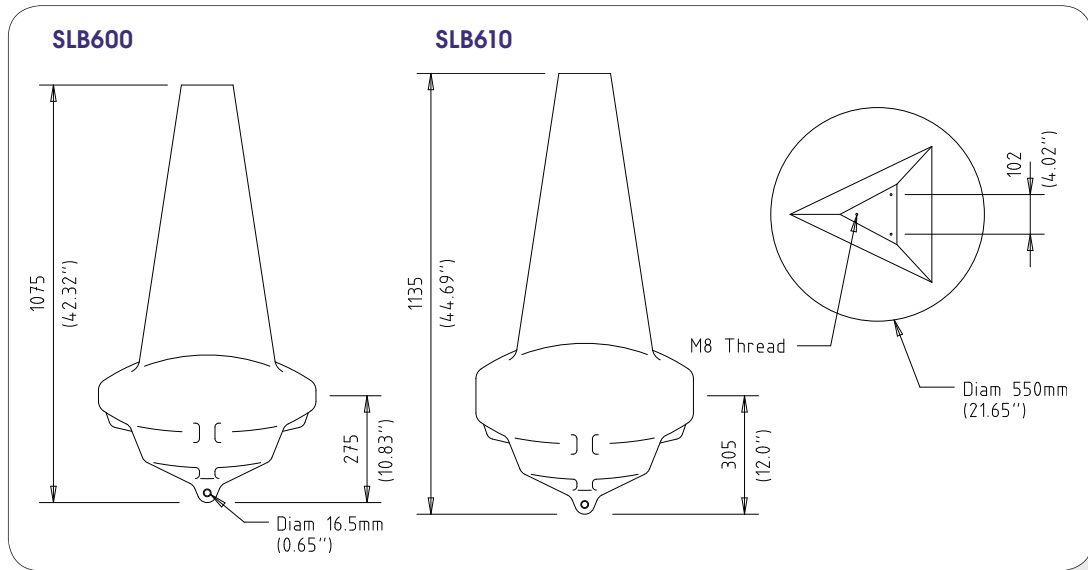

SPECIFICATIONS •

SLB600

SLB610 - with increased buoyancy

Available Colours	Red, Green, White, Yellow as per IALA Recommendations
Focal Plane Height (mm/inches)	900 / 35½
Material	Rotationally moulded UV stabilised virgin polyethylene
Wall Thickness (mm/inches)	6 / ¼
Ballast	Internal steel-shot
Foam Filling	Closed-cell polyurethane
Reserve Buoyancy (kg/lbs)	14 / 30
Draft (mm/inches)	275 / 10¾
Height (mm/inches)	1075 / 42⅓
Width (mm/inches)	600 / 23⅔
Mass (kg/lbs)	16 / 35¼
Quality Assurance	ISO9001:2000
Product Life Expectancy	Up to 12 years
Warranty	1 year
Options Available	

- Sealite lantern- SL15, SL60, SL70
- Mould-on graphics

Available Colours	Red, Green, White, Yellow as per IALA Recommendations
Focal Plane Height (mm/inches)	965 / 38
Material	Rotationally moulded UV stabilised virgin polyethylene
Wall Thickness (mm/inches)	6 / ¼
Ballast	Internal steel-shot
Foam Filling	Closed-cell polyurethane
Reserve Buoyancy (kg/lbs)	28 / 61⅔
Draft (mm/inches)	305 / 12
Height (mm/inches)	1135 / 44⅔
Width (mm/inches)	600 / 23⅔
Mass (kg/lbs)	16 / 35¼
Quality Assurance	ISO9001:2000
Product Life Expectancy	Up to 12 years
Warranty	1 year
Options Available	

- Sealite lantern- SL15, SL60, SL70
- Mould-on graphics

CE

• Specifications subject to change or variation without notice



Head Office:
Sealite Pty Ltd
AUSTRALIA

Ph. +61 3 5977 6128
Fax. +61 3 5977 6124
Internet: www.sealite.com.au
Email: info@sealite.com.au

USA Customers;
Sealite USA
USA (Gilford, NH)

Ph. (603) 524-6066
Fax. (603) 524-8100
Internet: www.sealiteusa.com
Email: info@sealiteusa.com

