

SL50 / SL52 Self-Contained Lanterns

This equipment complies with requirements of the U.S. Coast Guard in 33 CFR part 66

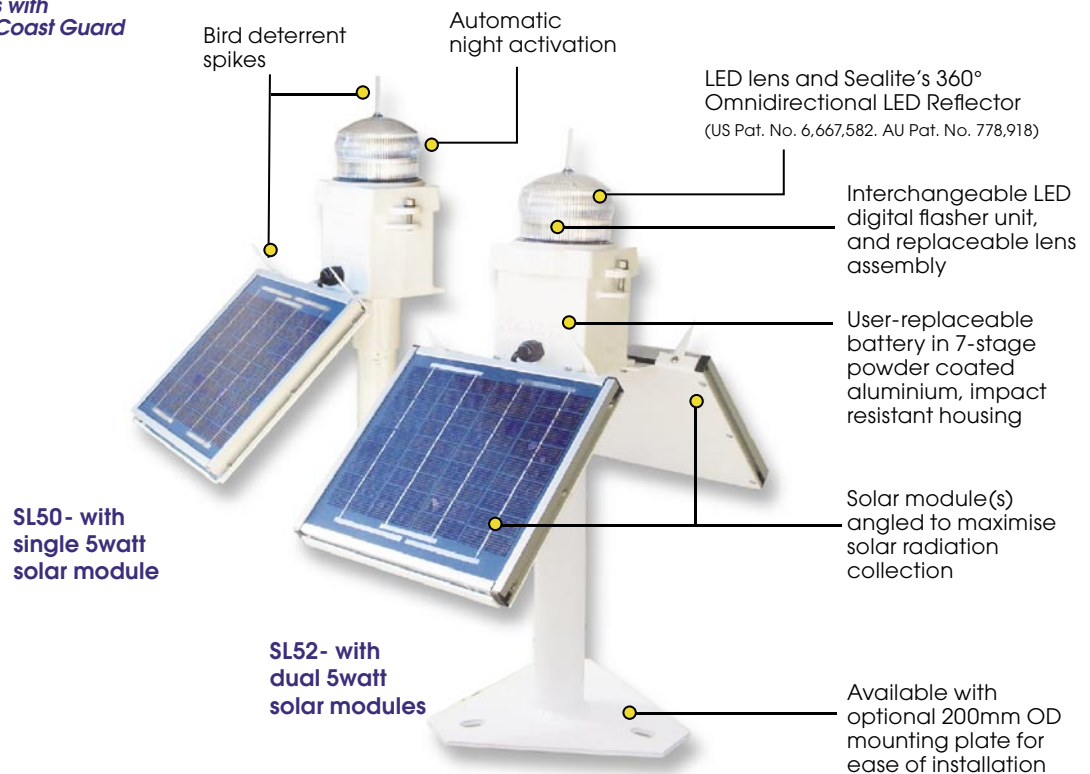

The Sealite Advantage

- 5watt solar module(s)
- 4.5Ah battery capacity
- 10 day autonomy
- Interchangeable 20 LED flasher units

The larger 5watt solar module(s) and 4.5Ah battery of the SL50 and SL52 lanterns allow the units to operate at higher duty cycles, or in lower sunlight regions.

The SL50 and SL52 lanterns have been widely adopted by professionals in the marine sector, including ports & harbours, transport departments and coast guards.

The lanterns are covered by the Sealite 3-year warranty, and all components are replaceable, and can be purchased individually in the unlikely event of damage to the unit.



Operational Area •

• Operational region maps are a guide only.



Head Office:
Sealite Pty Ltd
AUSTRALIA

Ph. +61 3 5977 6128
Fax. +61 3 5977 6124
Internet: www.sealite.com.au
Email: info@sealite.com.au

USA Customers:
Sealite USA
USA (Gilford, NH)

Ph. (603) 524-6066
Fax. (603) 524-8100
Internet: www.sealiteusa.com
Email: info@sealiteusa.com

SL50 / SL52 Self-Contained Lanterns

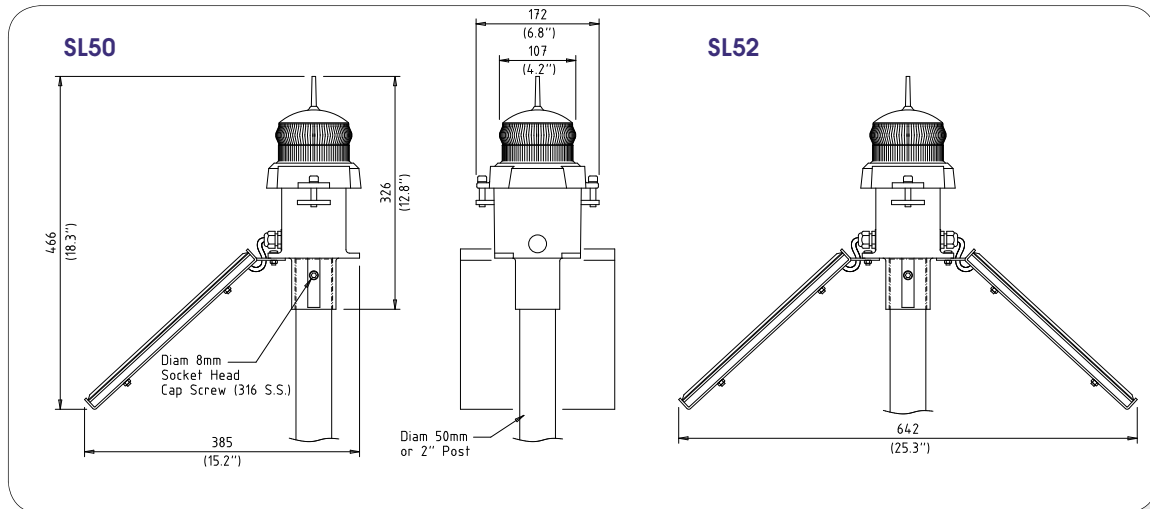

SPECIFICATIONS •

Light Characteristics

Light Source
Available Colours
Peak Intensity (cd)
Visible Range (nm)
Horizontal Output (degrees)
Vertical Divergence (degrees)
Reflector Type
Available Flash Characteristics
Intensity Adjustments
LED Life Expectancy (hours)

20 ultra-high intensity LEDs
Red, Green, White, Yellow, Blue
Refer to table on page 23
>3
360
9
Omnidirectional 360° LED Reflector (US Pat. No. 6,667,582. AU Pat. No. 778,918)
Up to 256 IALA recommended (user adjustable)
Adjustable in 25% increments
100,000

Electrical Characteristics

Current Draw (mA)
Circuit Protection
Operating Voltage (v)
Autonomy (days)

180 (nominal)
Integrated
12
>10 (14 hour darkness, 12.5% duty cycle)

Solar Characteristics

Solar Module Type
Output (watts)

Multicrystalline
SL50: 5 (1 x 5watt)
SL52: 10 (2 x 5watt)

Solar Module Efficiency (%)
Charging Regulation

14
Microprocessor controlled

Power Supply

Battery Type
Battery Capacity (Ah)
Nominal Voltage (v)

SLA (Sealed Lead Acid)
4.5
12

Physical Characteristics

Body Material
Lens Material
Lens Diameter (mm/inches)
Lens Design
Mounting
Height (mm/inches)
Width (mm/inches)

7-stage powder-coated aluminium
LEXAN® Polycarbonate – UV stabilised
107 / 4¹/₄
External optics with interior flute design
50mm OD pole
466 / 18¹/₃
SL50: 385 / 15¹/₄
SL52: 642 / 25¹/₃
SL50: 4 / 8³/₈
SL52: 4.5 / 9⁷/₈
Up to 12 years

Mass (kg/lbs)

Product Life Expectancy

Certifications

CE
Quality Assurance

EN61000-6-3:1997. EN61000-6-1:1997
ISO9001:2000

Intellectual Property

Patents
Trademarks

US Pat. No. 6,667,582. AU Pat. No. 778,918
SEALITE® is a registered trademark of Sealite Pty Ltd

Warranty

Options Available

3 years

- 200mm OD mounting plate
- Hard wire or GPS synchronisation

CE

• Specifications subject to change or variation without notice

Head Office:
Sealite Pty Ltd
AUSTRALIA

Ph. +61 3 5977 6128
Fax. +61 3 5977 6124
Internet: www.sealite.com.au
Email: info@sealite.com.au

USA Customers;
Sealite USA
USA (Gilford, NH)

Ph. (603) 524-6066
Fax. (603) 524-8100
Internet: www.sealiteusa.com
Email: info@sealiteusa.com

