

**MICROBOTICS APPLICATION NOTE**  
**GROUND/RETURN WIRING IN MULTI-MODULE SYSTEMS**  
**7 February 2007**

**1 Purpose.** The purpose of this application note is to outline proper system ground wiring when using a multi-module system such as the Microbotics Servo Controller/Safety Switch or Autopilot Platform with servos or other boards. Many system problems or operational “gremlins” can be traced back to improper ground return connections.

**2 Types of Ground/Return Lines.** A common misconception is all “grounds” are the same, and ground connections may be made at any ground pin. While an ohmmeter will show that all ground pins are actually connected together, each ground connection has specific uses, and not paying attention to these requirements can cause noisy operations, system malfunctions, or even destruction of the equipment. There are essentially four types of “grounds” or “returns”: safety grounds, power returns, digital returns, and analog returns.

The primary purpose of *safety grounds* is to protect the equipment and user in the event of a failure in power connections. In this type of failure, the currents created by the fault will flow directly into the ground circuit (usually tripping a circuit protection device) rather than pass through an unsuspecting user. The most common type of safety ground is a chassis connection that is connected, usually via the power cord, to an earthing contact. However, the safety ground often is used for the additional purpose of electrically shielding the equipment from RFI and EMI sources and/or to prevent internal electrical noise from affecting other systems.

*Power returns* are used to return the operational current to the power source, whether this is a power supply or a battery. Each powered piece of equipment usually has its own power return, and, ideally, each power return should be routed directly to the ground (negative) terminal of the power source.

*Digital returns* are used to reference the voltages of digital signals to the equipment logic power supplies. On the circuit boards, this functionality is performed by the ground planes. In board-to-board connections, this line connects to each board digital ground primarily to prevent these grounds from electrically “floating” too far from each other. If the grounds begin to have a potential difference (often occurring because independent power sources are used), a small current will be developed in the digital return, thus preventing any significant voltage to be developed between these grounds.

*Analog returns* (including RF grounds) are used to reference analog voltages between systems. However, this signal is primarily meant as a voltage reference, and is not meant to carry current. In normal usage, the receiving equipment would use a differential amplifier to measure the voltage between the signal and the analog return, thus canceling noise induced in the signal run.

**3 Using Ground Connections.** In an ideal application, a central ground contact would be established, and all grounds would be connected to this point. While this presents a good theory, it is seldom achievable in the real world, especially when sub-modules are fairly far apart within the vehicle (note that “far apart” has different meanings in different systems – in low noise, slow speed systems, this could be measured in feet, while in noisy environments using high-speed signals, this distance might be measured in inches). It is important to note that the information below is provided as guidelines only – since applications tend to be unique, each implementation must be reviewed individually.

**3.1 Safety Ground.** A full discussion of the uses of safety/shield grounding is beyond the scope of this application note. However, one point needs to be stressed. While it is common in the automotive industry, a safety ground (“chassis ground”) should *not* be used as a power return. Often in unmanned vehicles, the continuity of this ground cannot be guaranteed, resulting in an open power return. As the power supply current *will* find its way back to the power source, this inadvertent break will usually result in some form of failure in another ground path.

**3.2 Power Returns.** Power returns should be implemented in the heaviest wiring that can be reasonably supported by the vehicle design (the wire gauge chosen is often a compromise between lowest voltage drop at operational currents and weight/routing limitations of the vehicle). Each subsystem should use a separate return to the power source, or to a distribution block mounted closely to the power source. The principle here is to keep the voltage drop caused by the returning current as low as possible, and to reduce the inter-module interference caused by these voltage drops. When multiple modules use the same power return line, the voltage drops (and resultant noise) of the modules combine.

One often overlooked result of excessive noise on the power return line is this noise is often manifested as **power source** noise, and power bypassing often is insufficient to cope. This will result in such “gremlins” as servo chatter, servo searching, false triggering, and sensor inaccuracies.

In some cases, a power source return is routed to one module pin, and another ground pin of that module is used to route power returns to other modules. This forces all the downstream power to be returned through the module circuitry, circuitry that often cannot sustain these return currents. Unless the module has been specifically designed for this type of routing (e.g., power distribution blocks), this type of power return routing should **never** be used. The diagram below demonstrates some different power return routings.

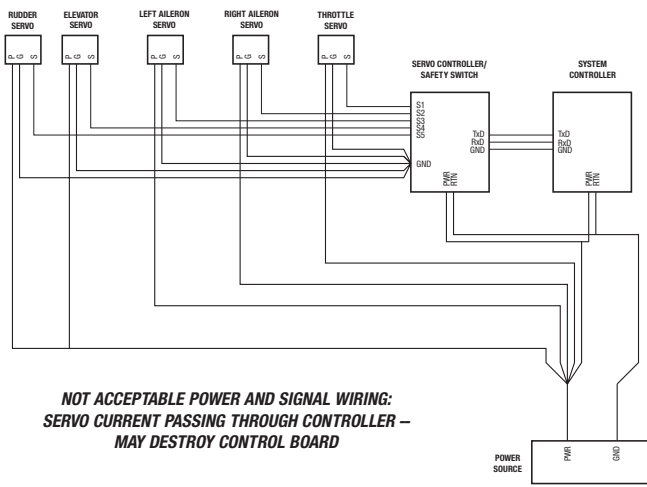
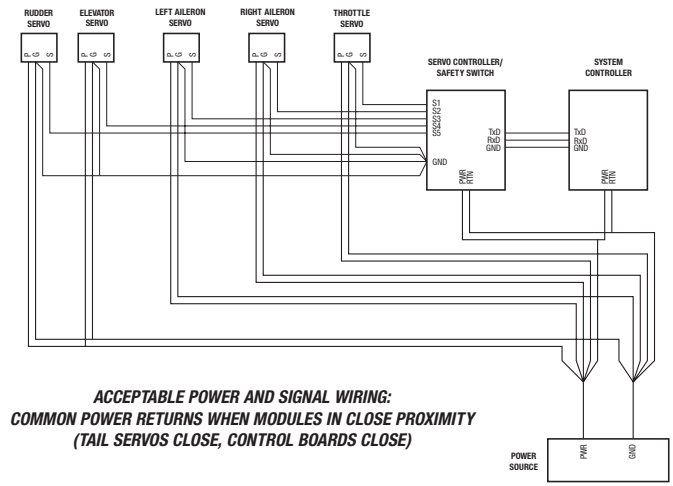
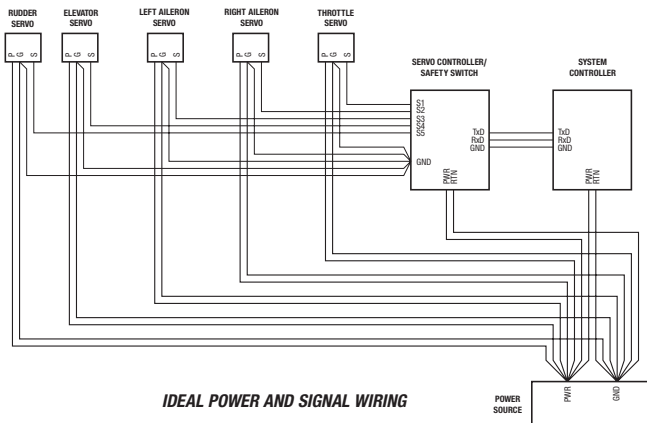

It is difficult to over stress the importance of proper power return wiring in any systems, especially when several modules use high currents (e.g., servos). The discussion below regarding digital and analog returns refer back to consequences of improper power return wiring.

**3.3 Digital Returns.** As digital returns are meant to reduce ground “float” between modules (trying to keep it less than  $\pm 250$  mv), they are usually implemented with small gauge wiring, and, in such an implementation, do not support any significant DC current. However, as these return signals are actually part of the electrical ground of the module, a failure in the continuity of the power return will most often force the power return current to flow through the digital returns.

As the digital returns are not designed for high currents, the most common result of this improper power current return is the destruction of the traces, wiring, and/or connector pins implementing the digital returns. Even if the digital return lines survive the over-current condition, excessive system noise will usually result due to the erratic, and often indeterminate, return path of the power current. Thus it is imperative in any vehicle design to make sure the power wiring is properly installed. Power source connections should never use a switch in the power return circuit (use switches only in the power source lines), as interrupting the power return will often create the above fault.

**3.4 Analog Returns.** With very few exceptions, an analog return is not designed to carry any current at all, but only provide a reference for voltage measurements. Often system designs will tie an analog return to the analog ground plane at the signal source while using this line for differential measurements at the destination module. Other designs actively drive the analog return lines to cancel system noise. Unless the system design specifically requires grounding of the analog returns, **never** tie an analog return to any pin other than that specifically designated for that analog return signal. Failure to follow this guideline will usually result in destruction of the analog circuitry of the module.